

ERWEITERUNGEN EXTENSIONS

AUFBAUANLEITUNG CONSTRUCTION MANUAL

DE

EN

INKLUSIVE
INCLUSIVE

MOBIL

POOL KLEIN • SMALL

POOL GROSS • LARGE

POOL XXL

TOR SET • GOAL SET

BALLCAGE

BUILD • CLIMB • DRIVE • SLIDE • SPLASH

tested • approved • recommended • worldwide • since 1979



INHALT • TABLE OF CONTENTS

▶▶ 6 Erweiterungen • 6 extensions

Seite • Page



QUADRO WÄCHST MIT IHREM KIND! QUADRO GROWS WITH YOUR CHILD!



Achtung: Vor dem ersten Gebrauch bitte die Sicherheitshinweise sorgfältig durchlesen!
Caution: Please read the safety instructions carefully before you start with assembling!



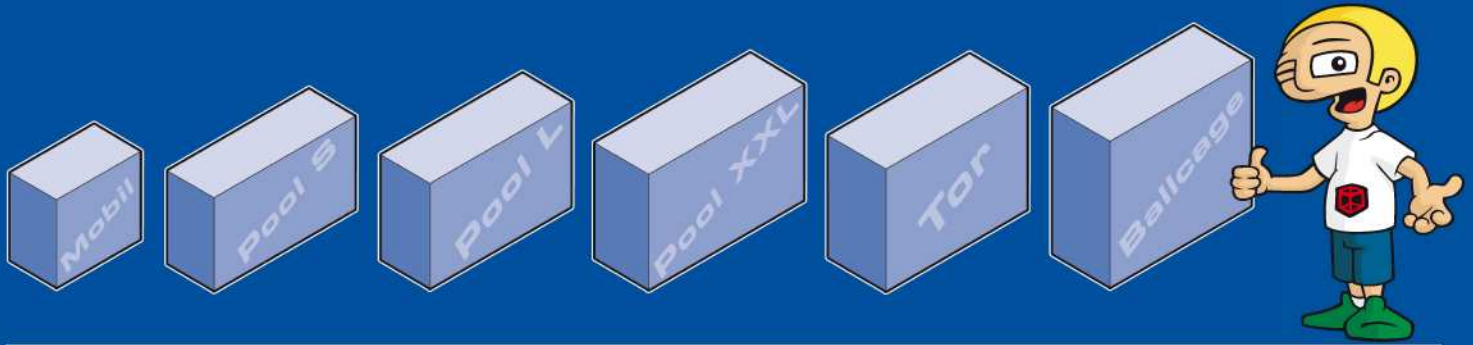

MOBIL

Mobil (Art. 10390) 15 Teile • 15 components

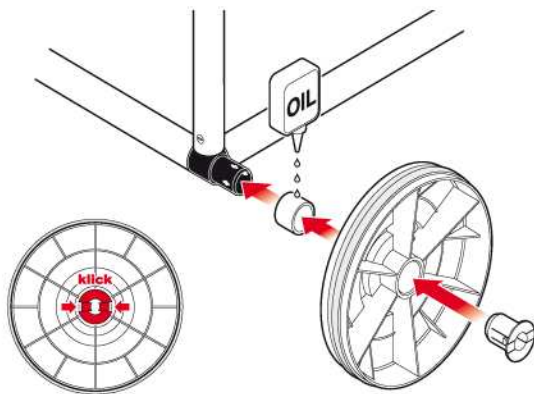

Multi Rad • Multi-wheel

Bespannen Sie das QUADRO Multi Rad vor dem Einbau in das QUADRO Modell mit dem QUADRO Laufreifen für ein besseres und leiseres Abrollverhalten.

Tip: Um das Bespannen des Multi Rades mit dem Laufreifen zu erleichtern, erwärmen Sie den Laufreifen vorher im warmen Wasser. Achten Sie darauf, dass sich das QUADRO Multi Rad bei der Montage in der korrekten Position befindet.

Tip: Verwenden Sie Schmiermittel zwischen QUADRO Radlager und QUADRO Multi Rad für ein besseres und längeres Laufverhalten.

Before assembling the multi-wheel in the QUADRO model, put the tread on the multi-wheel to achieve a smoother and more quiet rolling.

Tip: To facilitate the assembling of the tread to the multi-wheel, warm up the tread beforehand in a bit of warm water. Make sure that the QUADRO multi-wheel is in the correct position when assembling it.

Tip: Use some grease between the QUADRO bearings and the QUADRO multi-wheel to achieve a better and longer rolling of the wheel.



Laufrollen • Casters

Die Laufrollen werden mit Hilfe des Adapters und einer Rohrschraube an die dazugehörige Konstruktion montiert.

By using the adapters and the screw for tubes, the casters can be attached to the construction.

Multirad • Multi wheel	Laufreifen • Tread	Radlager • Bearing	Arretierung Steering lock	Laufrollen • Casters	Rohrschraube Tube screw	Schlüssel • Key
2x Art. : 00852 - 00855	2x Art. : 00895	2x Art. : 00501	2x Art. : 00835	2x Art. : 00008	2x Art. : 00612- 00615	1x Art. : 00675





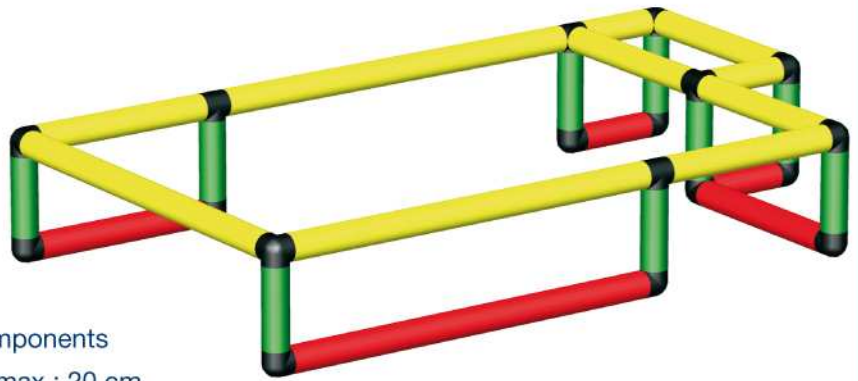







POOL KLEIN • POOL SMALL

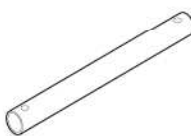

POOL S (Art. 10960) 99 Teile • 99 components

Wasserhöhe max.: 20 cm Water level max.: 20 cm

145 cm x 85 cm x 25 cm

Raumk. 4-armig 4 way connector  2x Art. : 00041	Raumk. 3-armig 3 way connector  6x Art. : 00031	Rohr (15 cm) Tube (15 cm)  13x Art. : 00512 - 00515	Rohr (75 cm) Tube (75 cm)  4x Art. : 00572 - 00575	Platte (40 x 20 cm) Panel (40 x 20 cm)  1x Art. : 00202 - 00205	Poolfolie klein Pool foil small  1x Art. : 10012	Schlüssel Key  1x Art. : 00675
Flächenk. 3-armig T connector  2x Art. : 00131	Flächenk. 2-armig (90°) Elbow connector  8x Art. : 00121	Rohr (35 cm) Tube (35 cm)  7x Art. : 00532 - 00535			Plattenschraube Panel screw  6x Art. : 00620	Rohrschraube Tube screw  48x Art. : 00612- 00615

POOL GROSS • POOL LARGE



Pool L (Art. 11670)









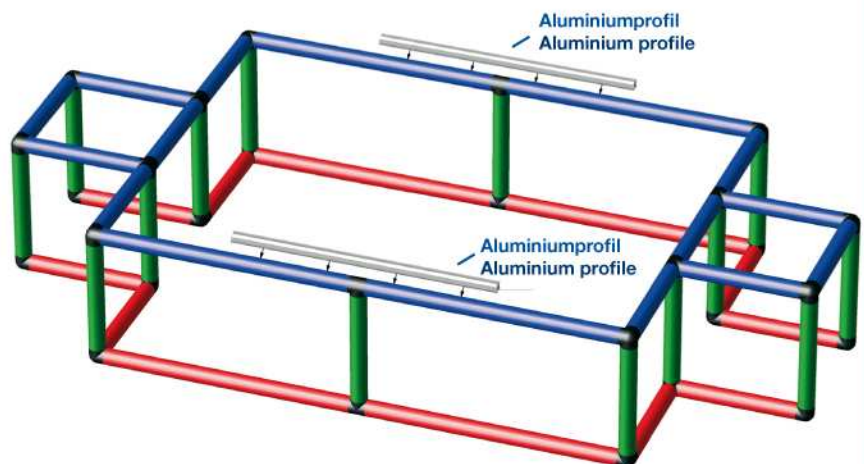

168 Teile • 168 components

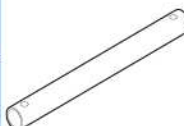
Wasserhöhe max.: 40 cm

Water level max.: 40 cm

245 cm x 125 cm x 45 cm



Raumk. 4-armig 4 way connector  4x Art. : 00041	Raumk. 3-armig 3 way connector  16x Art. : 00031	Rohr (75 cm) Tube (75 cm)  8x Art. : 00572 - 00575	Rohr (35 cm) Tube (35 cm)  34x Art. : 00532 - 00535	Platte (40 x 40 cm) Panel (40 x 40 cm)  2x Art. : 00402 - 00405	Poolfolie groß Pool foil large  1x Art. : 10022	Schlüssel Key  1x Art. : 00675
Flächenk. 3-armig T connector  4x Art. : 00131	Flächenk. 2-armig (90°) Elbow connector  4x Art. : 00121		Alu-Profil (75 cm) Alu profile (75 cm)  2x Art. : 40276		Plattenschraube Panel screw  8x Art. : 00620	Rohrschraube Tube screw  84x Art. : 00612- 00615



POOL XXL (Art. Nr. 11680)

246 Teile • 246 components

Wasserhöhe max.: 40 cm
Water level max.: 40 cm









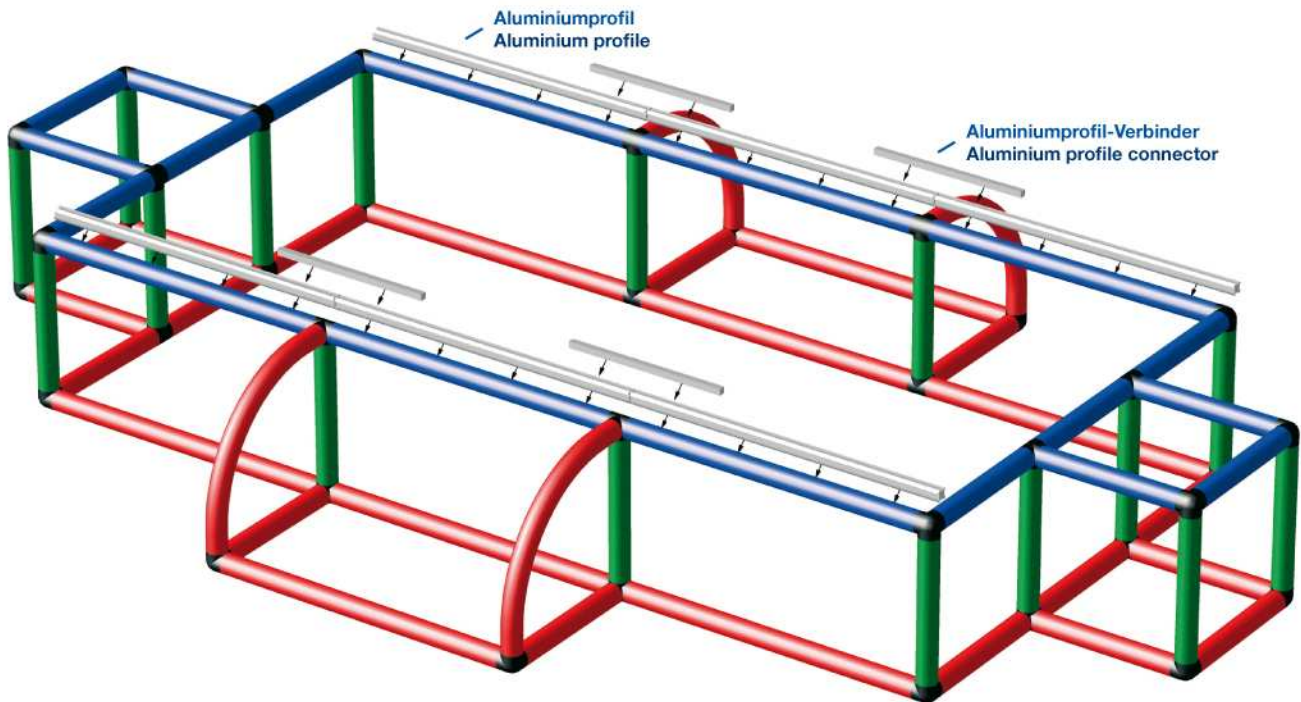
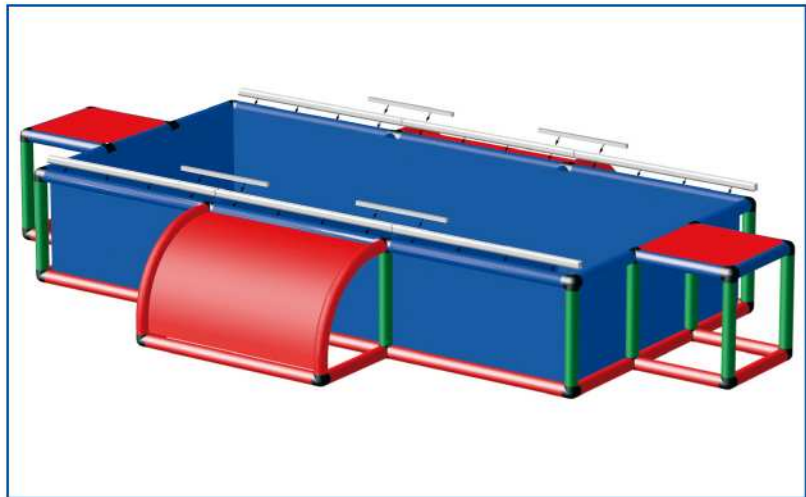



325 cm x 125 cm x 45 cm

Aluminiumprofil / Aluminium profile

Mehr Informationen über die Aluminiumprofile & Aluminiumprofil-Verbinder finden Sie in den Sicherheitshinweisen auf Seite 5, 1.12

You can find more information about the aluminium profile & aluminium profile connector in the Safety Instructions on page 5, 1.12



Raumk. 4-armig 4 way connector  16x Art. : 00041	Rohr (75 cm) Tube (75 cm)  14x Art. : 00572 - 00575	Rohr (35 cm) Tube (35 cm)  44x Art. : 00532 - 00535	Platte • Panel (40 x 40 cm)  2x Art. : 00402 - 00205	Poolfolie XXL Pool foil XXL  1x Art. : 10032	Rundtextil • Round textile  2x Art. : 00363	Schlüssel Key  1x Art. : 00675
Raumk. 3-armig 3 way connector  20x Art. : 00031	Bogenrohr Curved tube  4x Art. : 10052 - 10055	Alu-Profil (75 cm) Alu profile (75 cm)  6x Art. : 40276	Alu-Profil-Verbinder Alu profile connector  4x Art. : 40274	Plattenschraube Panel screw  8x Art. : 00620	Rohrschraube Tube screw  124x Art. : 00612- 00615	



TOR SET



Aluminiumprofil
Aluminium profile

Tor Set (Art. 10750) 109 Teile • 109 components

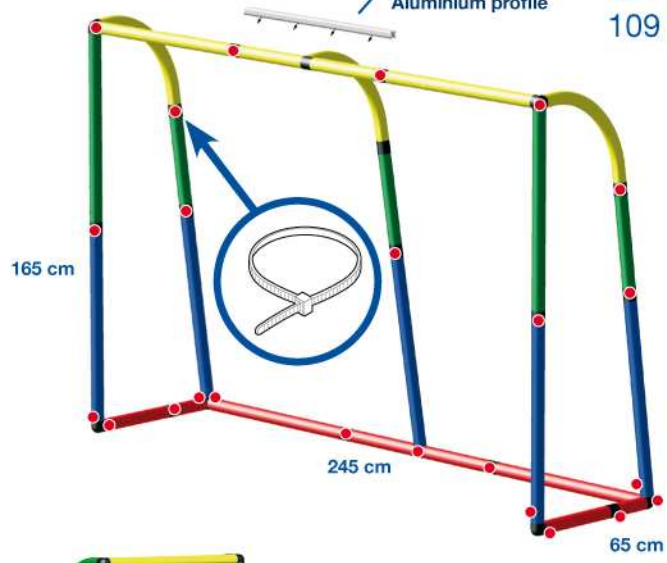

Kabelbinder • Cable straps

Befestigen Sie alle QUADRO Kabelbinder gleichmäßig an der Außenseite des Tores um das Tornetz fixieren zu können.

Connect all QUADRO Cable straps equally to the outer part of the goal to be able to attach the net on the exterior of the goal.

Flügelschraube • Netclip

Eine alternative Methode, um das Tornetz zu befestigen, finden Sie in den Sicherheitshinweisen auf Seite 5, 1.11.









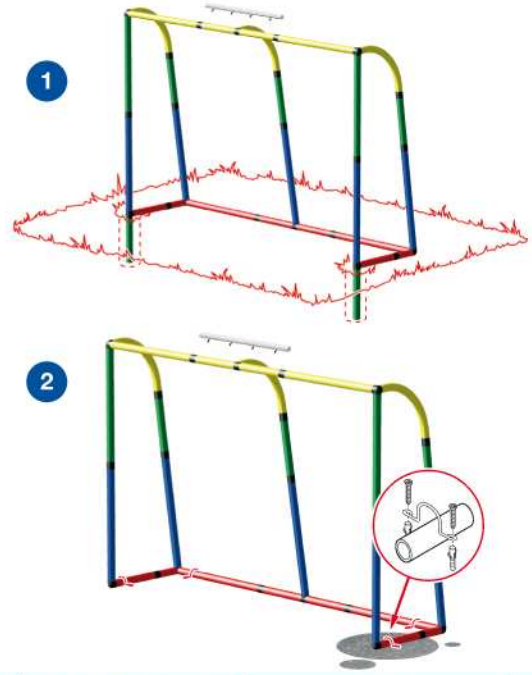
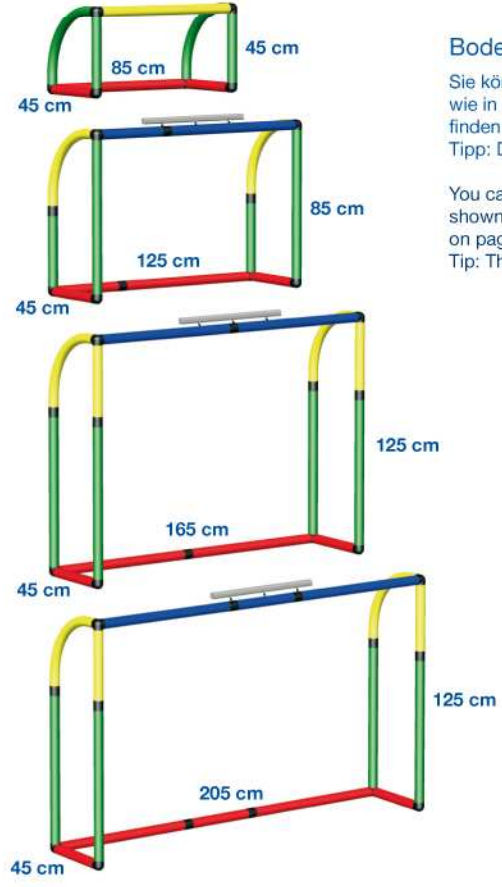

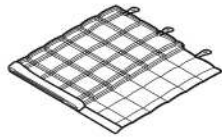

An alternative method to connect the goal net you'll find in our construction manual on page 5, 1.11.

Bodenverankerung • Anchoring on the ground

Sie können das Tor auch im Boden verankern. Hierzu befolgen Sie bitte die Bauweise, wie in Abb. 1 oder 2 dargestellt. Hinweise wie die Bodenverankerung eingebaut wird, finden Sie auch in den Sicherheitshinweisen auf Seite 9, 5.1.
Tipp: Die Bodenverankerung passt für jede Torgröße!

You can also attach the goal to the ground. Therefore please assemble the model as shown in figure 1 or 2. For more information please take a look into the Safety Instructions on page 9, 5.1
Tip: The anchoring is suitable for every goal size!



Raumk. 3-armig 3 way connector  4x Art. : 00031	Flächenk. 3-armig T connector  4x Art. : 00131	Rohr (15 cm) Tube (15 cm)  2x Art. : 00512 - 00515	Bogenrohr • Curved tube  3x Art. : 10052 - 10055	24 Kabelbinder • 24 Cable straps  1x Tüte/Bag Art. : 00666	Tornetz Net for goal  1x Art. : 10223	Schlüssel Key  1x Art. : 00675
F.k. 2-armig (90°) Elbow connector  2x Art. : 00121	F.k. 2-armig (180°) 2 way connector  14x Art. : 00111	Rohr (35 cm) Tube (35 cm)  11x Art. : 00532 - 00535	Rohr (75 cm) Tube (75 cm)  11x Art. : 00572 - 00575	Alu-Profil (75 cm) Alu profile (75 cm)  1x Art. : 40276	Rohrschraube Tube screw  54x Art. : 00612-00615	

Ballcage (Art. 11040) 102 Teile • 102 components

Hinweis: Für den Ballcage benötigen Sie den Pool Groß.
Tipp: Das große Cover (Art. 00010) ist nicht im Ballcage enthalten und kann separat bestellt werden.
Advice: To assemble the ballcage a large pool is required.
Tip: The large cover (Art. 00010) is not included in the ballcage and can be ordered separately.

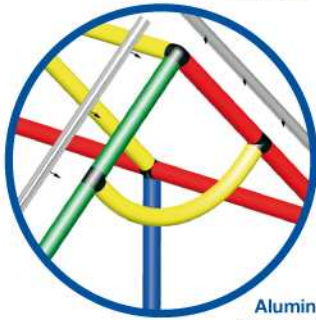
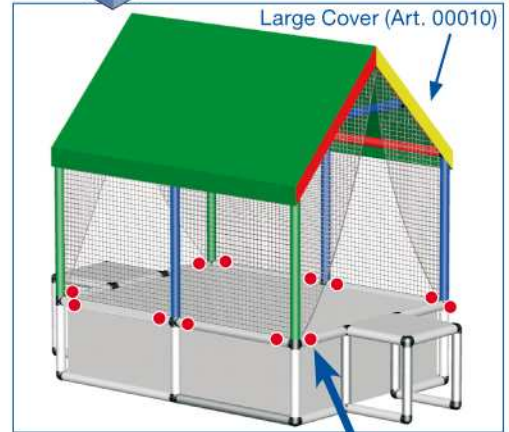

Alternative Konstruktion
Alternative construction

Aluminiumprofil
Aluminium profile

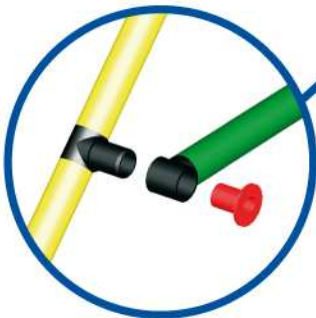















Arretierung • Steering lock

Befestigen Sie die Lochzapfenkupplung mit Hilfe der Arretierung entsprechend der Abbildung.

Please connect the hole connector by using the steering lock as shown in the figure.

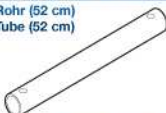

Flexikupplung
Flexi connector

<p>Raumk. 4-armig 4 way connector</p>  <p>5x Art. : 00041</p>	<p>Raumk. 3-armig 3 way connector</p>  <p>2x Art. : 00031*</p>	<p>Flexikupplung Flexi connector</p>  <p>6x Art. : 00071</p>	<p>Rohr (35 cm) Tube (35 cm)</p>  <p>8x Art. : 00532 - 00535</p>	<p>Alu-Profil (75 cm) Alu profile (75 cm)</p>  <p>4x Art. : 40276</p>	<p>Ballcage Netz Net for ballcage</p>  <p>1x Art. : 10233</p>	<p>Rohrschraube Tube screw</p>  <p>48x Art. : 00612- 00615</p>	<p>Arretierung Steering lock</p>  <p>4x Art. : 00835</p>
<p>Flächenk. 4-armig Cross connector</p>  <p>2x Art. : 00141</p>	<p>Flächenk. 3-armig T connector</p>  <p>4x Art. : 00131*</p>	<p>Lochzapfenkupplung Hole connector</p>  <p>4x Art. : 00841</p>	<p>Rohr (75 cm) Tube (75 cm)</p>  <p>14x Art. : 00572 - 00575</p>	<p>Rohr (52 cm) Tube (52 cm)</p>  <p>2x Art. : 40522 - 40525</p>	<p>24 Kabelbinder 24 Cable straps</p>  <p>1x Tüte/Bag Art. : 00666</p>	<p>Schlüssel Key</p>  <p>1x Art. : 00675</p>	

* = 2 Teile durch Pool groß * = 2 pieces with pool large



ERWEITERUNGEN EXTENSIONS

MOBIL



Art. : 103 90

POOL KLEIN • SMALL

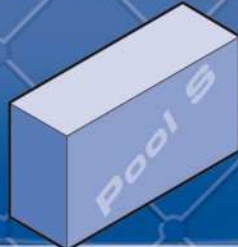

Art. : 109 60

POOL GROSS • LARGE



Art. : 116 70

POOL-XXL



Art. : 116 80

TOR SET • GOAL SET



Art. : 107 50

BALLCAGE



Art. : 110 40

INTEGRALRUTSCHE
INTEGRATED SLIDE



Art. : 100 40

BOGENRUTSCHE
CURVED SLIDE



Art. : 100 20

TEXTIL SET • TEXTILE-SET

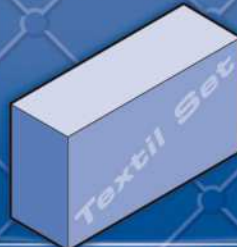

Art. : 003 50



QUADRO THE GIANT CONSTRUCTION KIT

Grossmoorbogen 15 | 21079 Hamburg | Germany
Tel. 0049 40 79 00 50 80 | Fax 0049 40 52 98 23 32
info@quadroworld.com | www.quadroworld.com

Elbring 12 | 21217 Seevetal | Germany
Tel. 0049 40 70 10 333 | Fax 0049 40 70 10 33 40
info@quadro.de | www.quadro.de

BUILD • CLIMB • DRIVE • SLIDE • SPLASH

tested • approved • recommended • worldwide • since 1979

